

Ax1

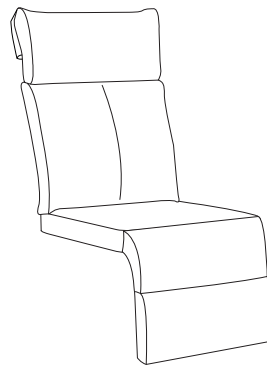

Bx1



1

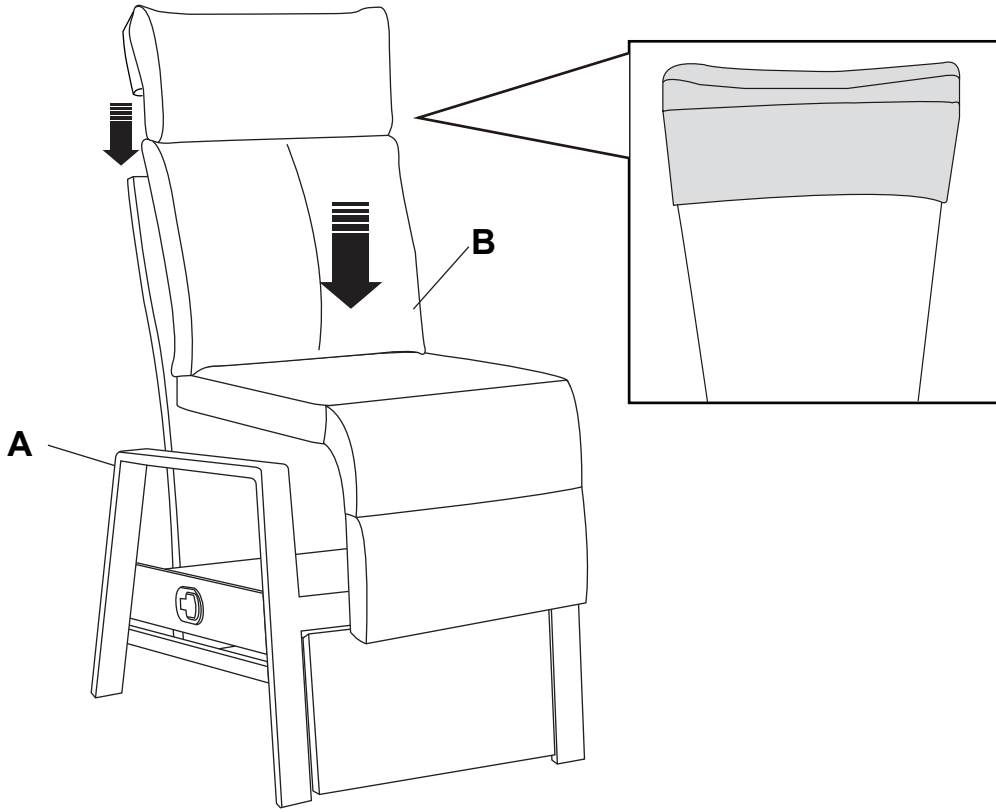

2

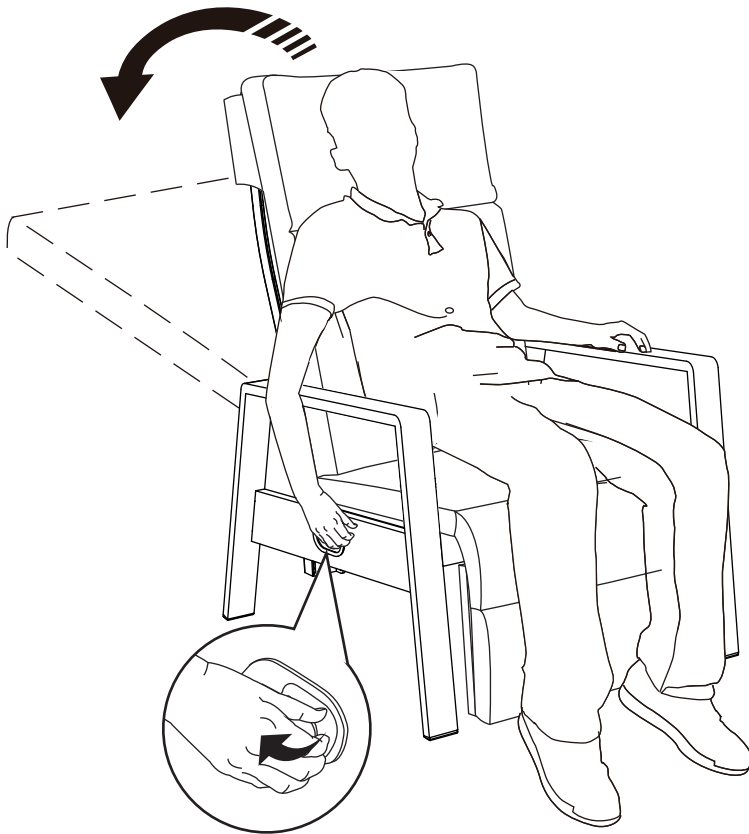

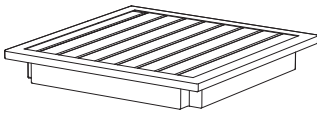
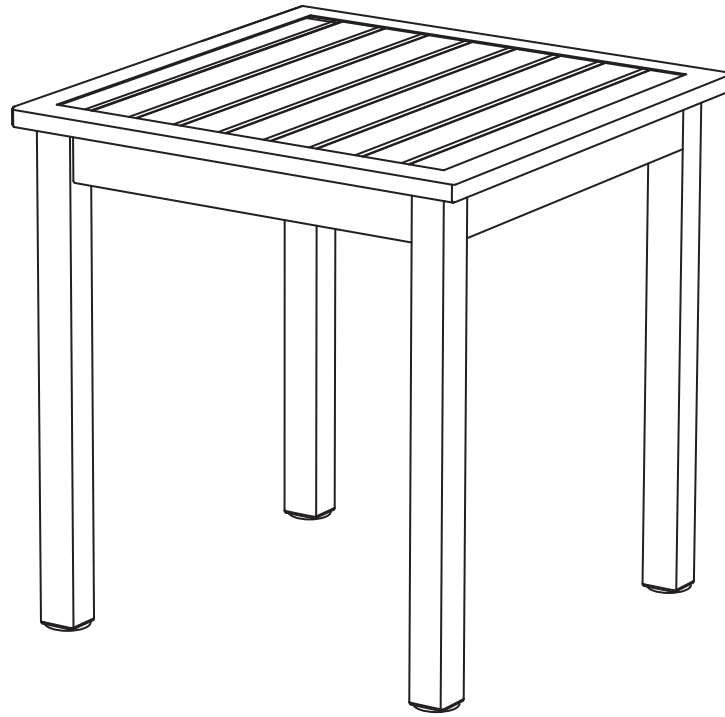

① x1



② x4



Ax8



Bx8

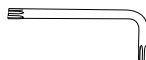

Cx1

1

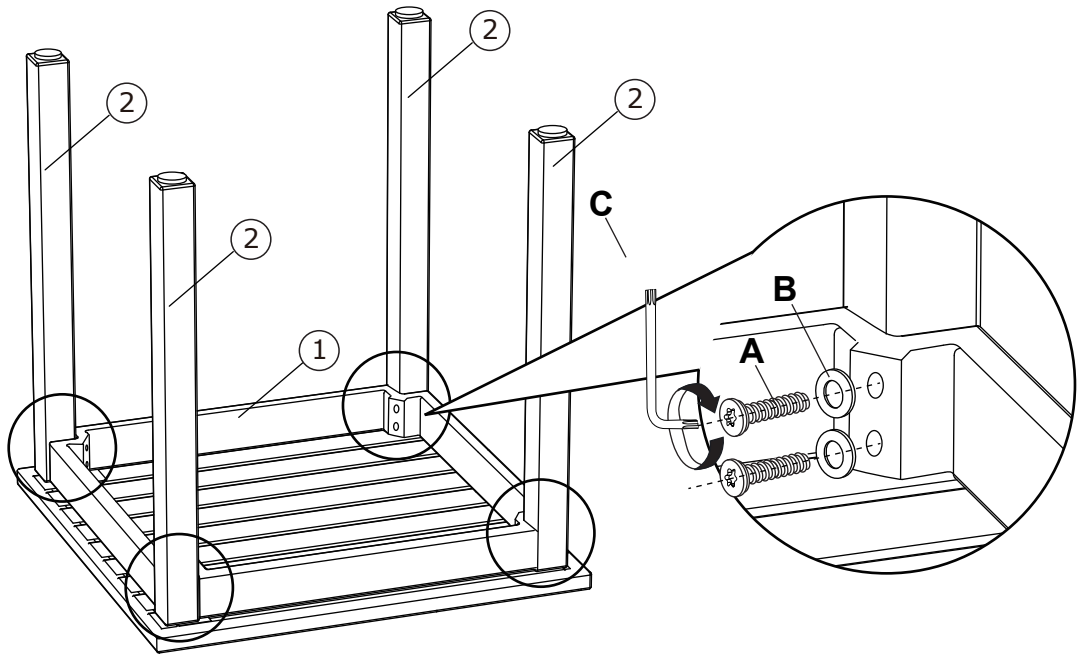

2

